

# 1/2 – 4 HOUR FIRE RATED STEEL DOOR



## PRODUCT DESCRIPTION

1/2 - 4 hour GI Steel Doors are reinforced with steel stiffener to enhance the overall rigidity and strength of the door.

Tested in accordance with Singapore Standard SS 332, 1998 and British Standard BS 476 part 22, 1976.

Doorset and Ironmongery used are approved by FSB, tested and labeled by PSB.

Products is certified to ISO 9002 : 1994.

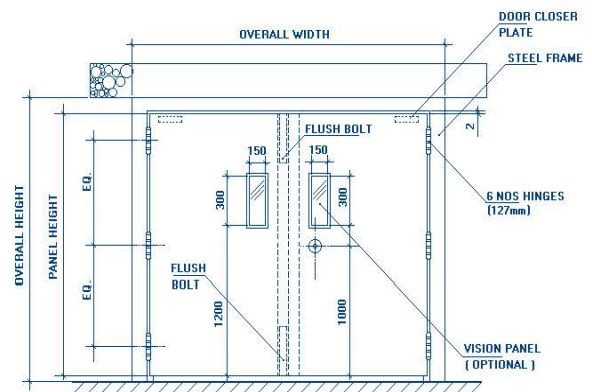

## PRODUCT SPECIFICATION

- 1) Door Leaf Construction  
Door leaf is constructed with 1.2mm thick Electro-Galvanised Steel. The front and bottom panels are formed into a 'U' shape with steel stiffeners stitch welded on the front panel at 300mm part. The front and bottom panels are interlocked and spots welded on the edges and at the top and bottom channel cover. Hinge plates and reinforce doors closer plates are tack welded in position internally.
- 2) Door Frame Construction  
Door Frames of single or double rebates are formed with 1.5mm thick Electro-Galvanised Steel, welded 90 degree at the top and side jambs. Reinforced steel plates for door closer and selector bar are welded on the top jamb. A temporary bar is tack welded at the bottom for installation purpose.
- 3) Door sizes (maximum)  
Single Leaf : Overall Dimension 1088mm (width) x 2400mm (height) x 45mm (thick)  
Double Leaf : Overall Dimension 22600mm (width) x 2400mm (height) x 45mm (thick)
- 4) Fire Seal  
Ceramic fibre tape - - used on vision panels
- 5) Accessories  
Vision Panel - 100mm (width) x 600mm (height) size of Fire Rated Glass, enclosed with steel Architrave.
- 6) Ironmongeries  
Hinges – Stainless Steel 127mm x 89mm x 3mm (thick)  
Lockset – ADH Cylindrical Lockset or equivalent.  
Door closer – TS 83 Dorma or equivalent.  
Flush Bolt – Stainless Steel 172mm by 26mm length.
- 7) Type of Door Finish  
Spray Paint or Powder Coated  
Vinyl Laminate
- 8) Test Report Number  
WARRES No. 100357 (4 hour)

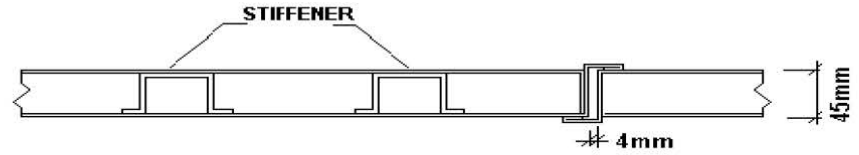
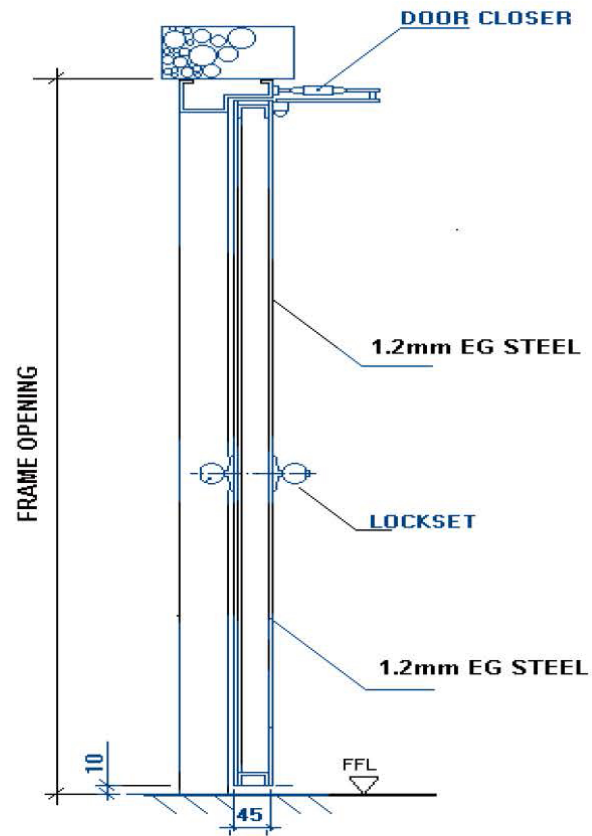

MEETING STILE : STIFFENER DETAIL

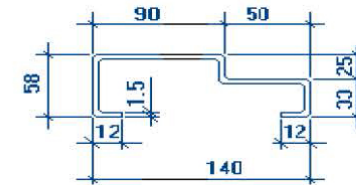

STEEL FRAME PROFILE 1.5 E.G.

FRAME PROFILE : SINGLE / DOUBLE (TIMBER OR STEEL)

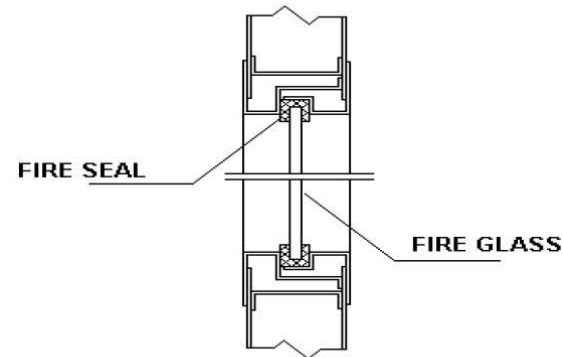

DETAIL OF VISION PANEL

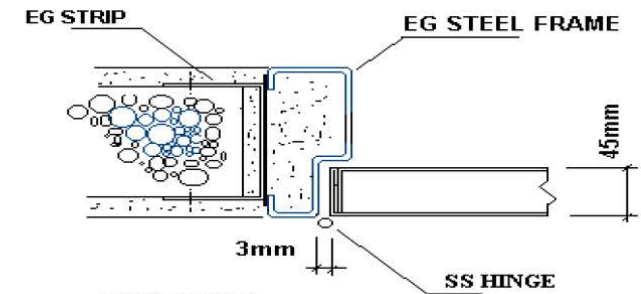

JAMB DETAIL

**1/2 - 4 HOUR FIRE RATED STEEL**